



eADLs

Our little friends

A SYSTEM WITH POTENTIAL

LSE Gateway

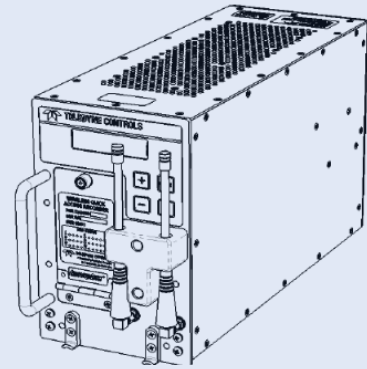

WQAR



DAL

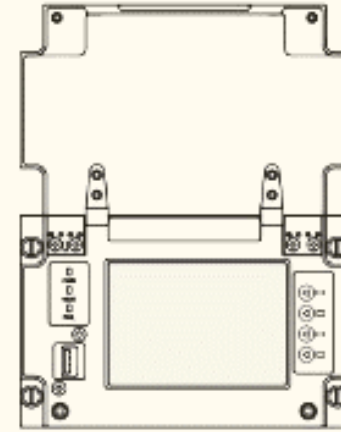

eADL

ATSU/DFDAU

LRUs

LRUs

LRUs

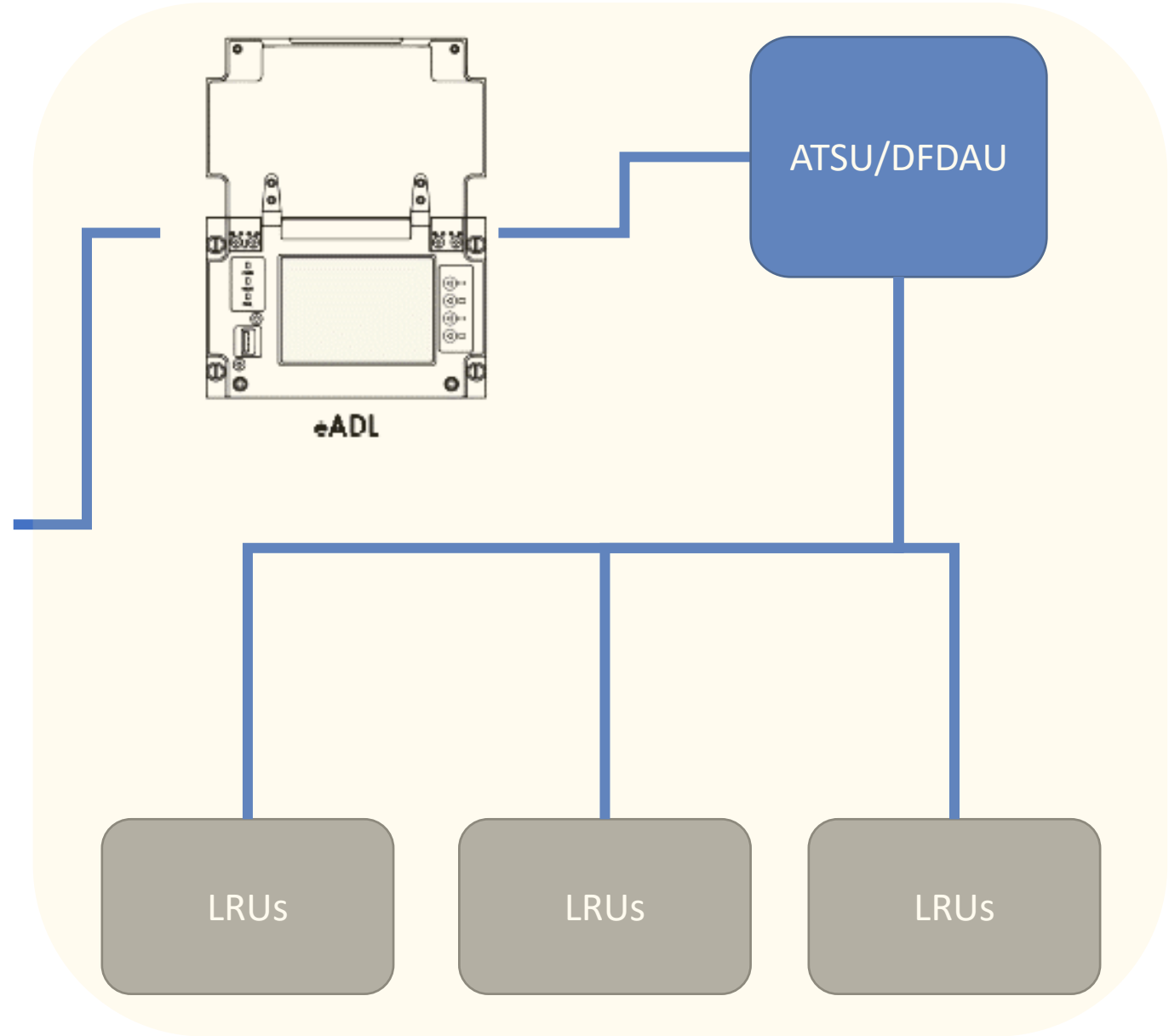

...TO REPLACE PMATS

LSE Gateway

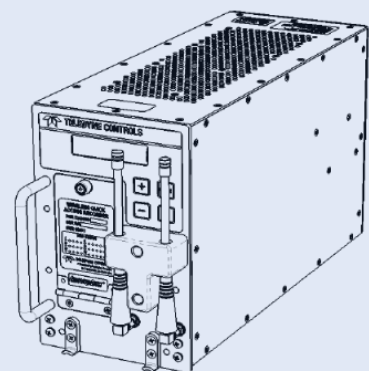

WQAR



DAL

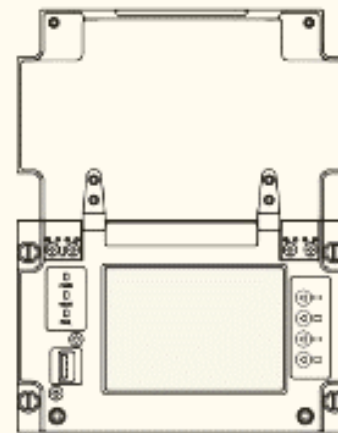

eADL

ATSU/DFDAU

LRUs

LRUs

LRUs

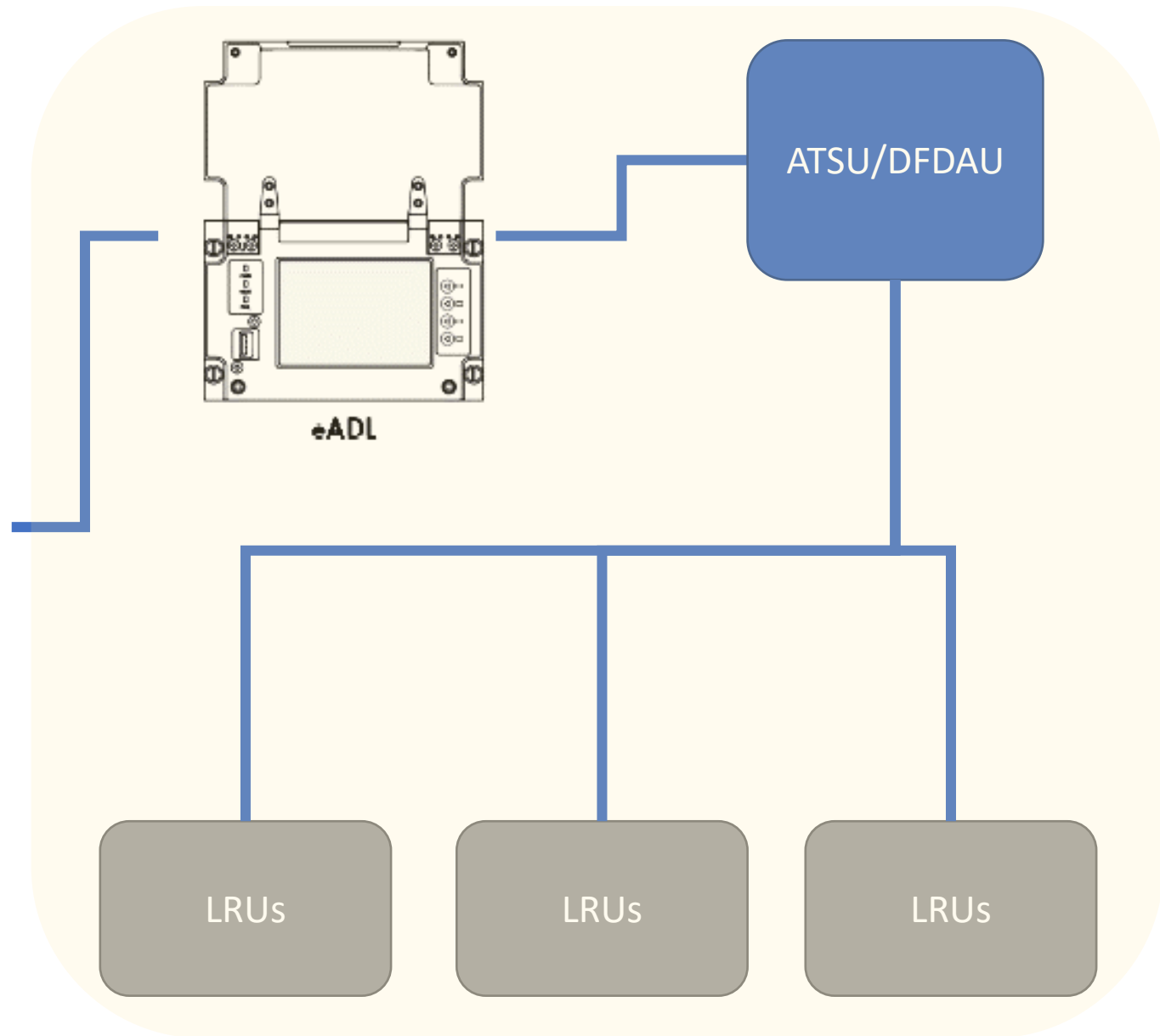

SO MANY NO WORKY

321	eADL 3018	green	Normal	green					WQAR - fixed	YES		tbody replaced, FRAI	fixed
321	eADL 3020	Blue	Normal	red	48.8	4/2/2007		DAL2.2211.001					
321	eADL 3048	blue	Normal	red	80.7	4/3/2007	TDY4E-7117-4506	DAL2.2211.001, ITESF7798860019	MSD full				
321	eADL 3057	blue	Normal	red	53.3	10/28/2007		4 pieces of software	delay				
321	eADL 3064	NOT ON REPORT	NOT ON REPORT	red	76	12/16/2021	TDY4E-7117-4506	many pieces of software	WQAR				
321	eADL 3070	NOT ON REPORT	NOT ON REPORT	red	67.9	4/3/2007	TDY4E-7117-4506	DAL2.2211.001	WQAR - KNDwN tail number incorrect				
321	eADL 3079	No eADL Status file download within 48 hrs	Normal	red	41.7	10/26/2022	TDY4E-7117-4506	DAL2.2211.001	switch file				
321	eADL 3085	NOT ON REPORT	Normal	red	10	12/28/2021		ALL SOFTWARE	switch file		2466369	WQAR software verification and loading using a PMAT.	(deferred)
321	eADL 3086	green	Normal	red	58.3	10/28/2022		A FEW	delay				
737	eADL 3774	Normal	No download within 48 hrs	green					(CHECK)				
737	eADL 3775	orange	Normal	red	65.2	4/3/2007		A FEW	MSD full, switch file				
737	eADL 3776	NOT ON REPORT	Normal	red	68.9	4/2/2007	3 PIECES OF SOFTWARE	MANY	MSD full, switch file				
737	eADL 3805	No eADL Status file download within 48 hrs	No download within 48 hrs	red	69.4	10/10/2022		2 PIECES OF SOFTWARE	CHECK				
737	eADL 3811	No eADL Status file download within 48 hrs	No download within 48 hrs	red	71.1	10/20/2022		DAL3.2211.001	WQAR				
737	eADL 3812	No eADL Status file download within 48 hrs	No download within 48 hrs	red	69.4	10/7/2022		2 PIECES OF SOFTWARE	WQAR				
737	eADL 3823	orange	Normal	red	67.7	4/2/2007		5 PIECES OF SOFTWARE	MSD full, switch file				
737	eADL 3845	NOT ON REPORT	Normal	red	68.8	10/28/2022		3 PIECES OF SOFTWARE	switch file				
737	eADL 3851	NOT ON REPORT	Normal	red	53.8	4/2/2007		MANY	switch file				
737	eADL 3854	NOT ON REPORT	NOT ON REPORT	red	69.2	9/23/2022		2 PIECES OF SOFTWARE	WQAR				
737	eADL 3855	No eADL Status file download within 48 hrs	Normal	red	70.5	10/25/2022		DAL3.2211.001	switch file				
737	eADL 3870	No eADL Status file download within 48 hrs	No download within 48 hrs	red	67.7	10/12/2022		2 PIECES OF SOFTWARE	WQAR				
737	eADL 3875	No eADL Status file download within 48 hrs	Normal	red	67.7	10/13/2022		2 PIECES OF SOFTWARE	switch file				
737	eADL 3878	Blue	Normal	red	0.6	10/28/2022		2 PIECES OF SOFTWARE (not NAV database)	delay				
737	eADL 3882	NOT ON REPORT	Normal	red			NOTHING	NO SOFTWARE	WQAR, eADL never set up				
737	eADL 3892	NOT ON REPORT	NOT ON REPORT	red	1.2	9/21/2022		2 PIECES OF SOFTWARE	WQAR				
737	eADL 3917	NOT ON REPORT	No download within 48 hrs	red	1.2	4/2/2007		2 PIECES OF SOFTWARE	WQAR				
737	eADL 3924	No eADL Status within 30 days	Normal	red	1.7	4/5/2007		4 PIECES OF SOFTWARE	switch file				
737	eADL 3931	NOT ON REPORT	NOT ON REPORT	red					SW SW...				

Just look at it

31 eADL SHOULD BE UPDATING AUTOMATICALLY

But aren't

INFORMATION SOURCES

WGL Aircraft Download Report

(absent)

RED

ORANGE

GREEN

no download within 30 days

no download within 48 hrs

a download is in progress

download achieved within 48 hrs

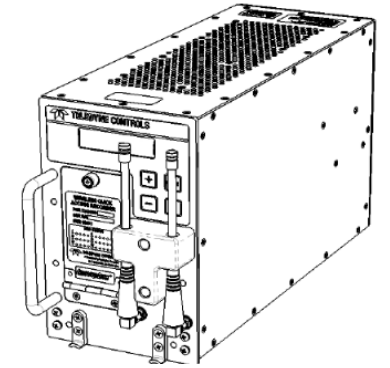

WQAR

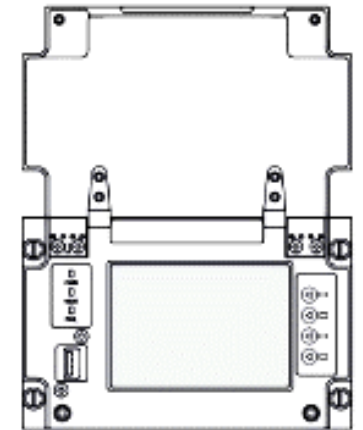

eADL

INFORMATION SOURCES

WGL Data Loading Report

(absent)

RED

ORANGE/BLUE

GREEN

no eADL download within 30 days

no eADL download within 48 hrs

a file upload occurred within 48 hrs

normal status

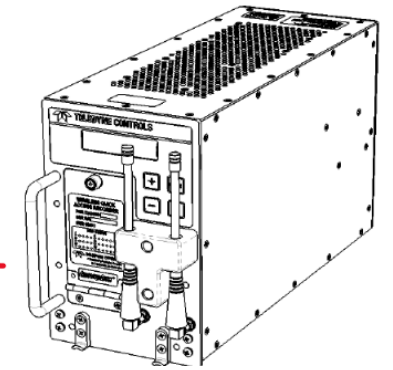

WQAR

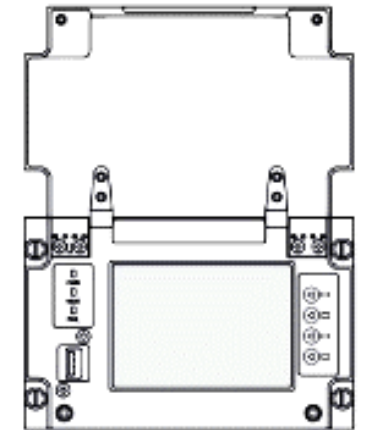

eADL



INFORMATION SOURCES

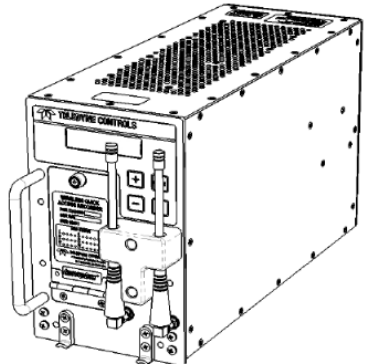

WQAR

LSE

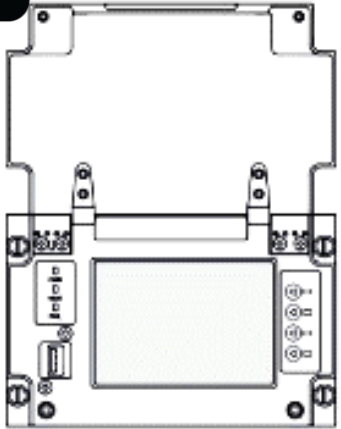

ADL

LSE

RED

ORANGE

GREEN

Installed vs. Assigned software mismatch
Software present but not installed
All Assigned software is installed, all installed software is assigned.

WHICH IS THE PROBLEM?

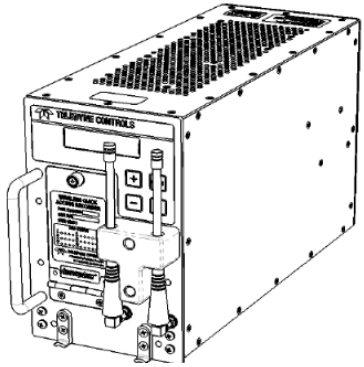

WGL Aircraft Download Report

RED

GREEN

GREEN

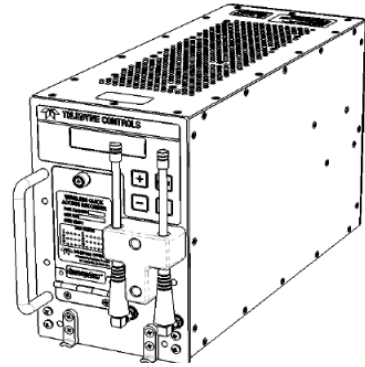

WQAR

WGL Data Loading Report

RED

RED

GREEN

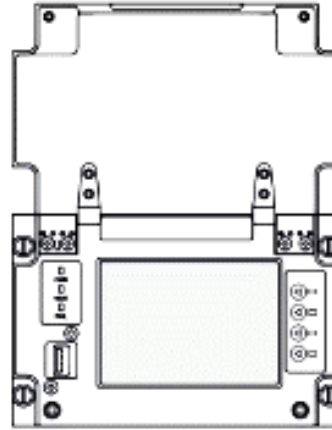

eADL

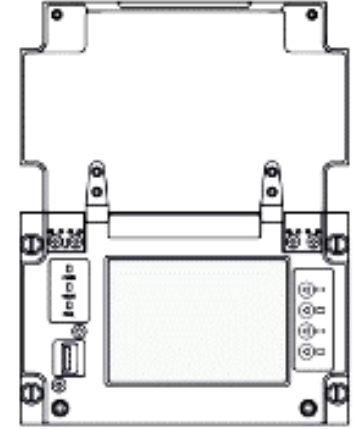

eADL

LSE

RED

RED

RED

WHICH IS THE PROBLEM?

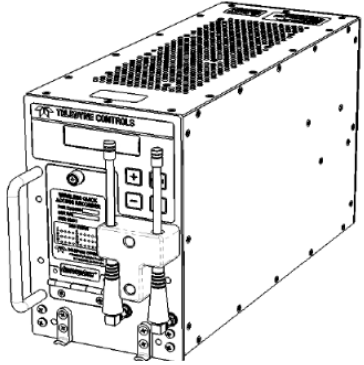

WQAR

WGL Aircraft Download Report

RED

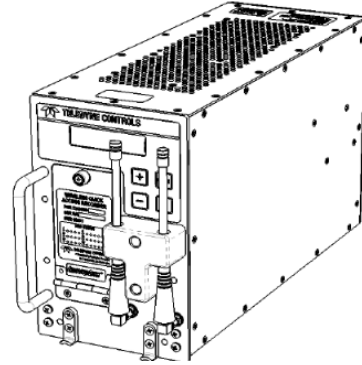

WQAR

WGL Data Loading Report

RED

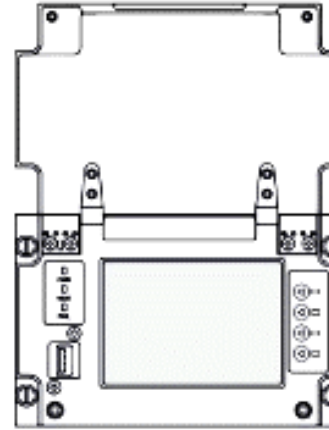

eADL

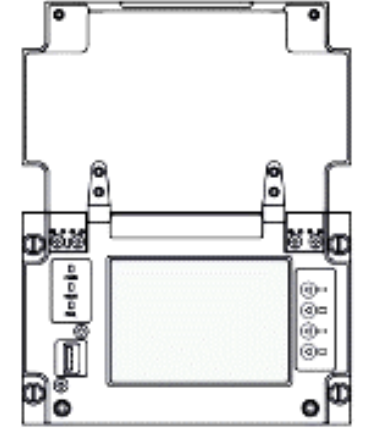

eADL

LSE

RED

→ WQAR needs troubleshooting (James's project)

Known causes:

- Incorrect tail number associated
- SIM card not installed appropriately
- OPS software incorrect

WHICH IS THE PROBLEM?

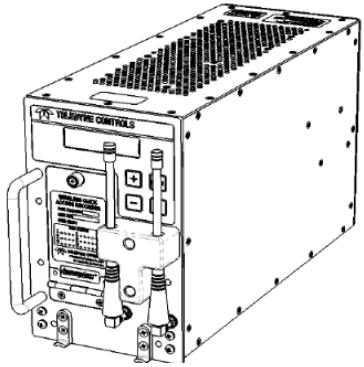

WQAR

WGL Aircraft Download Report

GREEN

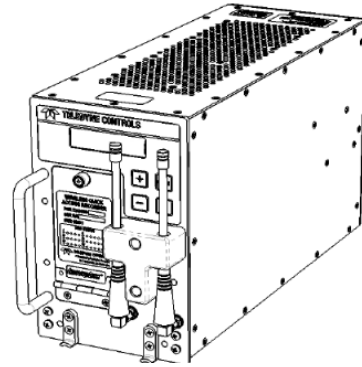

WQAR

WGL Data Loading Report

RED

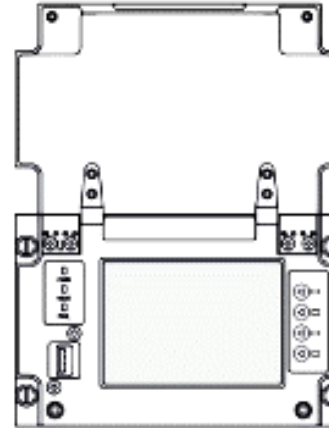

eADL

WGL Data Loading Report

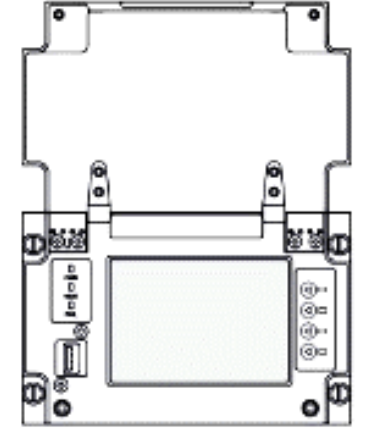

eADL

LSE

RED

➔ The connection between the WQAR and the eADL needs troubleshooting

Known causes:

- Incorrect or missing Switch and TMI Software
- Cable loose or damaged

WHICH IS THE PROBLEM?

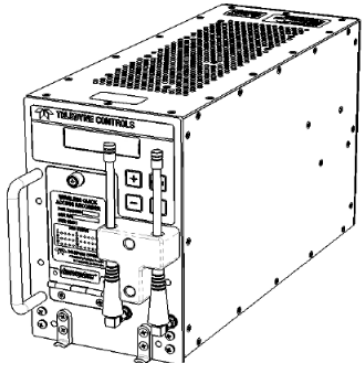

WQAR

WGL Aircraft Download Report

GREEN

→ eADL itself needs troubleshooting

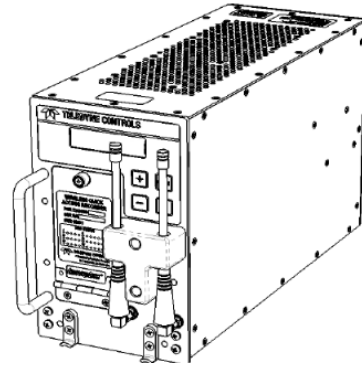

WQAR

WGL Data Loading Report

GREEN

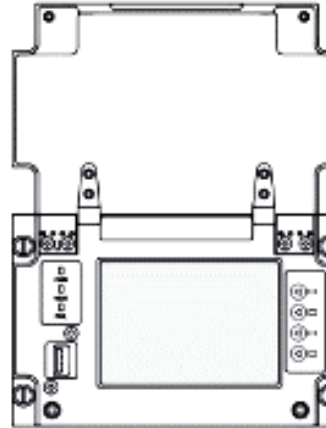

eADL

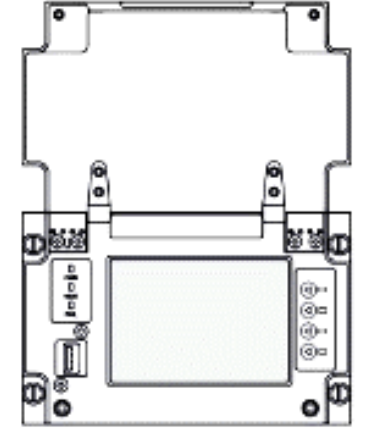

eADL

LSE

RED

Known causes:

- MSD too full
- Wrongfully assigned software on LSE

GAME PLAN

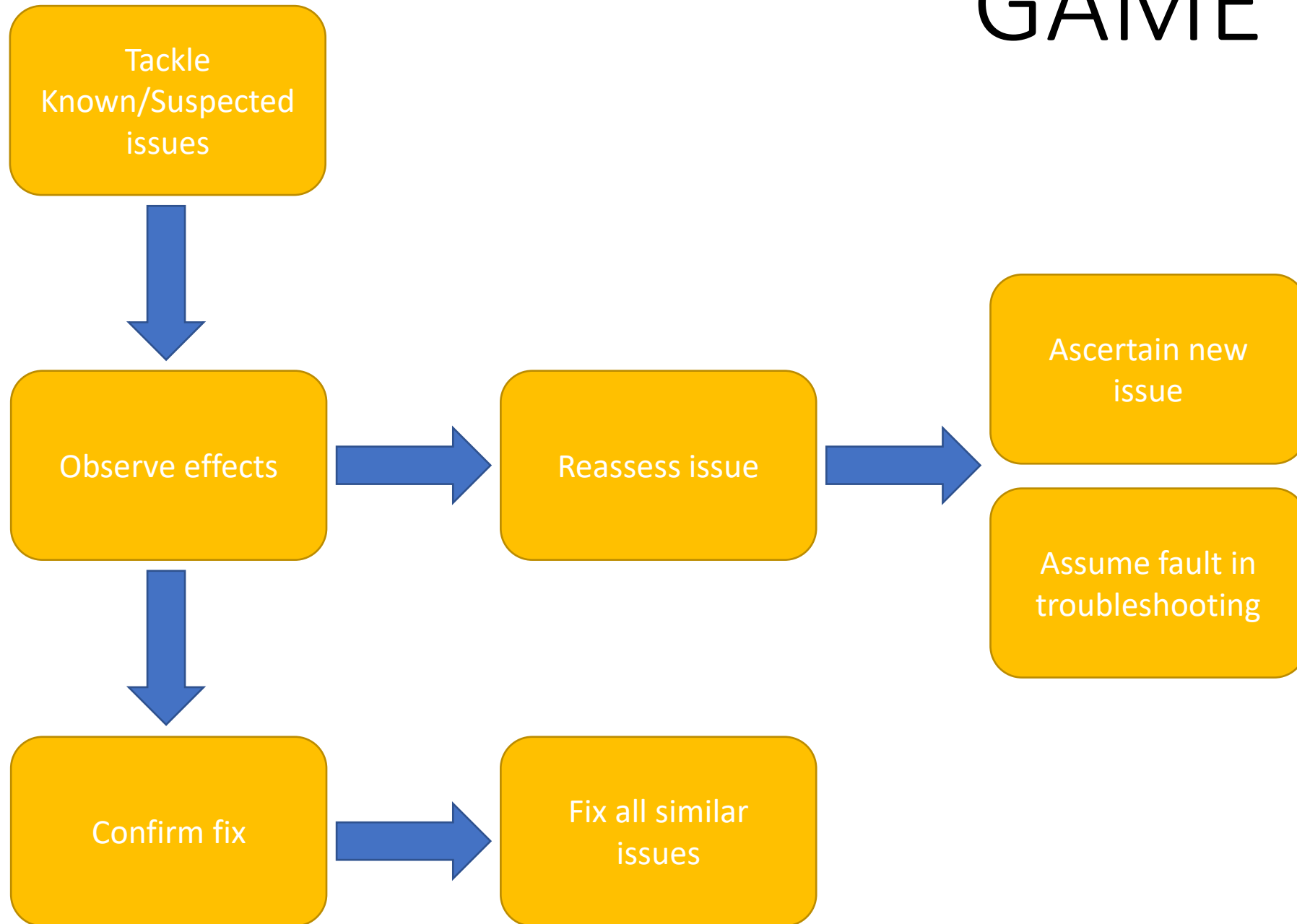

GAME PLAN

Tackle Known/Suspected issues

LSE and WQAR are both RED, meaning WQAR Switch/TMI software files suspected missing/incorrect

Log file written to install incorrect or missing S/W to WQAR

Observe effects

LSE and WQAR upload report still indicating RED

Reassess issue

Troubleshoot for eADL problems (MSD too full)
Contact Teledyne for help

Ascertain new issue

Assume fault in troubleshooting

Confirm fix

LSE and WQAR uploading now GREEN

Fix all similar issues

Tackle all tail numbers with the same problem

Rewrite log page for clarity, try again

SO FAR...

Successful fixes include:

- Switch file installed → At least 3 A/C fixed
- WQAR box replaced → 2 A/C fixed (James)
- Fixed software mismatch on OLSC due to 3G-4G AA clean-up error → 5 A/C fixed

Mysteries remaining:

- Delay effect?
- Boxes yo-yoing back and forth
- MSD troubleshooting not accomplished yet

Roadblocks:

- No more Bruce ☹️
- Deferral of log pages
- Working with Line Planning necessitates a one-by-one approach
- Circumventing of eADLs without log page causes mysteries